

site tabulation-retail

TABULATIONS	BLDG AREA	PRK'G REQ'D
Anchor	67,000	1:200 335
Best Buy	30,038	1:200 151
Retail	16,800	1:200 84

TOTAL	113,838	570
PARKING PROVIDED**		595
TOTAL SITE AREA (Including Pad Sites)	23.77 AC	
PAD SITE AREA	± 12.55 ac	

* Parking spaces in Major Anchor lot are 9'x19' w/ 25' drive aisle.
 ** Pad Site areas not included in calculations above.

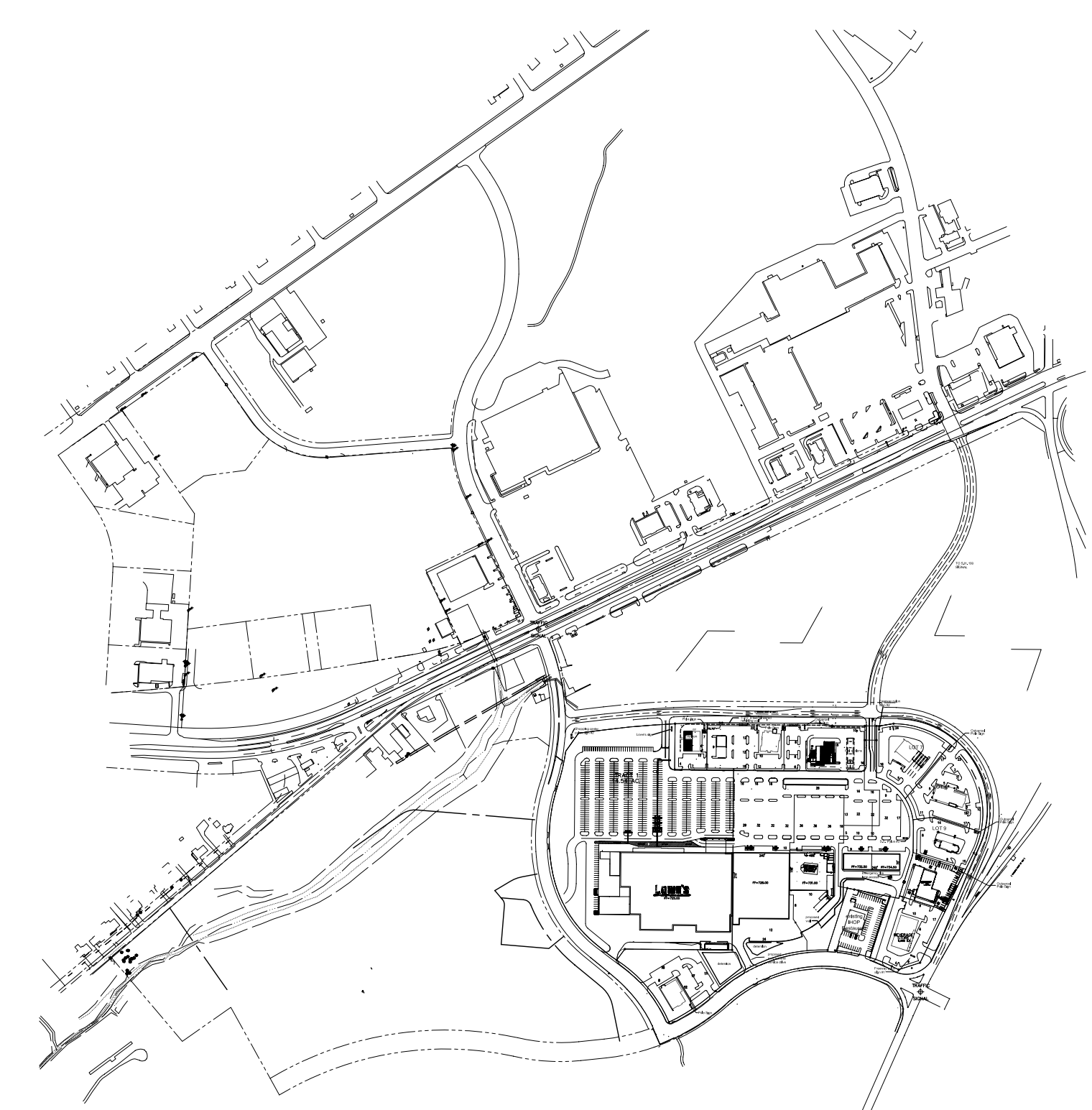

vicinity map

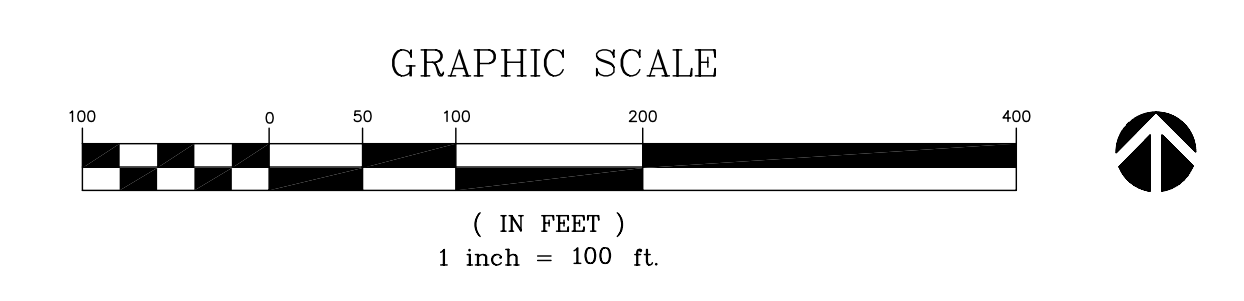

preliminary plan

Landmark Lakes II

Fort Worth, Texas

Landmark Loop 820 Ltd.
 Wilson & Stonaker, LLC.
 325 Miron, Suite 110
 Southlake, Texas 76092
 817-329-2929 817-329-2996 (fax)

ROBERT W. KELLY
 ARCHITECT INC.
 126 SOUTH MAIN STREET #100
 FORT WORTH, TEXAS 76104
 817-332-5014 FAX: 817-332-5570

DATE
 05-10-05

SCHEME
 SP-3